



LED LIGHT

Your Best Choice



www.lltgmbh.com

Contents

- Company Overview
- Our Products
- Our Projects
- Quality
- Contact



Company Overview

LED LICHT Your Best Choice present to the easiest and most dependable way to modified, energy-productive and future-evidence lighting arrangements. In the dynamic and ever progressively complex lighting market, clients are given ideal guidance, ideal direction and wonderful light. To guarantee this, LED LICHT offers a wide arrangement of innovations and administrations just as elite accomplices and organizations in the LED LICHT





The lighting expert consolidates single segments to make specially crafted total arrangements – in every case entirely customized to the client's prerequisites and explicit applications. Thusly, intricate and broad activities can be just and quickly executed from a solitary provider. In the soul of YOUR BEST CHOICE, straightforward arranging, establishment and usability are centered around for client arrangements notwithstanding quality and effectiveness.

The background features a dark teal gradient with several overlapping, semi-transparent geometric shapes in shades of teal and blue. A prominent, bright blue light beam or lens flare originates from the top right corner and extends towards the center, creating a sense of depth and focus.

Our Products

INDOOR LIGHTS

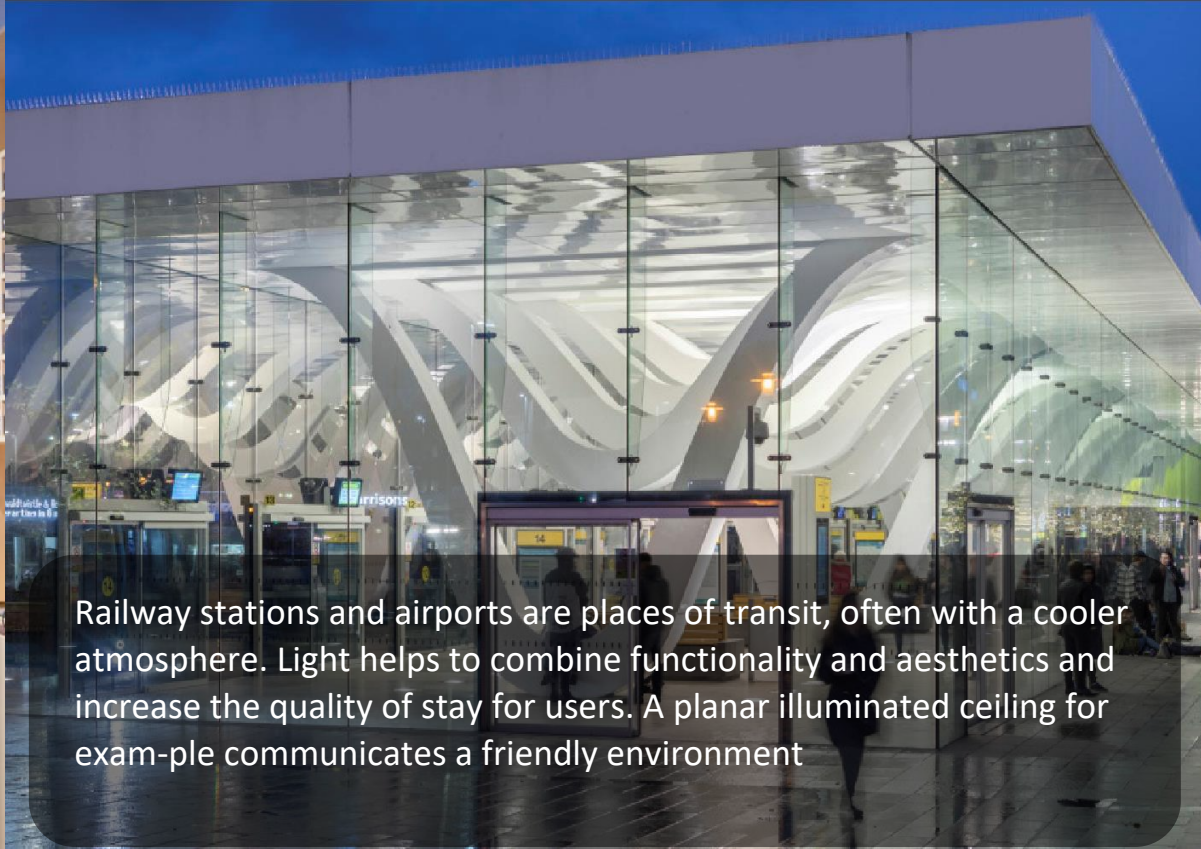

Railway stations and airports are places of transit, often with a cooler atmosphere. Light helps to combine functionality and aesthetics and increase the quality of stay for users. A planar illuminated ceiling for example communicates a friendly environment

OUTDOOR LIGHTS

Light transforms gardens and patios into an experience in the evening hours. LED LICHT luminaires with narrow light distributions create focal points for high quality environments at night.





Our Applications

MORE THAN JUST LIGHT







PRODUCT QUALITY



LED LICHT implies client explicit designs creating items with and for its clients arranged decisively their necessities. LED LICHT offers market consistent and future confirmation lighting arrangements coordinated to the particular necessities of the different applications.

DESIGN QUALITY



LED LICHT lighting ideas adjust to the by and large compositional idea of a structure. It involves supplementing the engineering with great lighting. We build up our items in close collaboration with eminent lighting fashioners, and such products are consistently awarded design prizes

LIGHT QUALITY



LED LICHT lighting arrangements offer substantially more than simply standard consistent lighting. They can be adjusted separately to altogether different requirements, supporting clients in their daily work task.

DATA QUALITY



LED LICHT accompanies and drive forward this transformation in the planning of building constructions with BIM by providing extensive product documentation leads the way in the industry

Work – indoor and outdoor luminaires for office and administration buildings

The lighting of office buildings encompasses more than the workplace and meeting rooms – it also includes the path and facade lighting outdoors. Concentrated work demands pleasant work surroundings with high visual comfort. As well as appropriate illuminance levels, this also includes optimum glare control and the balancing effect of vertical illuminance. A particular strength of LED LITCH is its downlights for track – a flexible and economical alternative to classic recessed luminaires.

Find out more:
www.lltgmbh.com

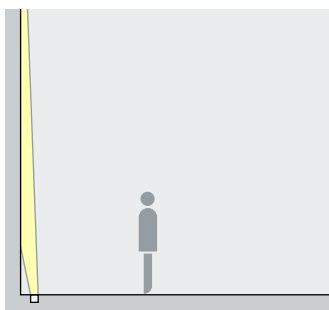

Outdoors: Representing with light

Facades, entrances and reception areas are the first opportunities for companies to present their corporate identity via the office architecture. Light sculpts the architecture and subtly communicates attributes such as openness and transparency.

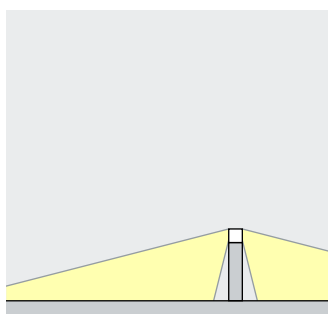

Vertical light for the first impression

Wallwashing communicates a welcoming gesture in the reception area. Bright walls lend the room depth and create a high impression of brightness. When wallwashed, foyers with glazed facades for example can be viewed from the outside and communicate a sense of openness and transparency to customers, employees and suppliers.

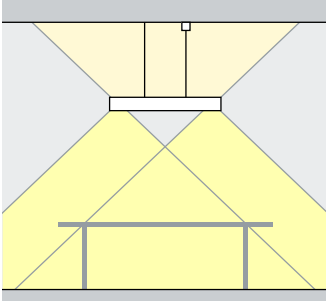
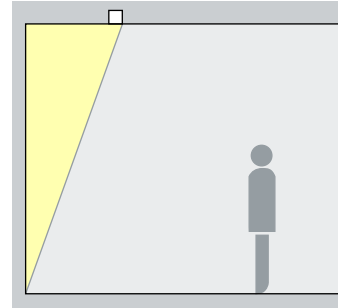

Illuminating conference rooms

Direct, personal discussions enable efficient agreement processes in daily work. For a harmonious impression during discussions at conference tables or during video conferences, good lighting is indispensable both for discussion participants and the room itself.



Work – indoor and outdoor luminaires for office and administration buildings

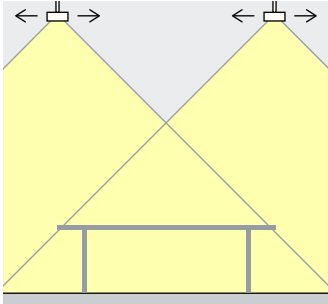

Flexible workstation lighting

Modern companies work with changing teams and methods. Downlights that can be moved in the track are the ideal solution for a flexible office infrastructure.

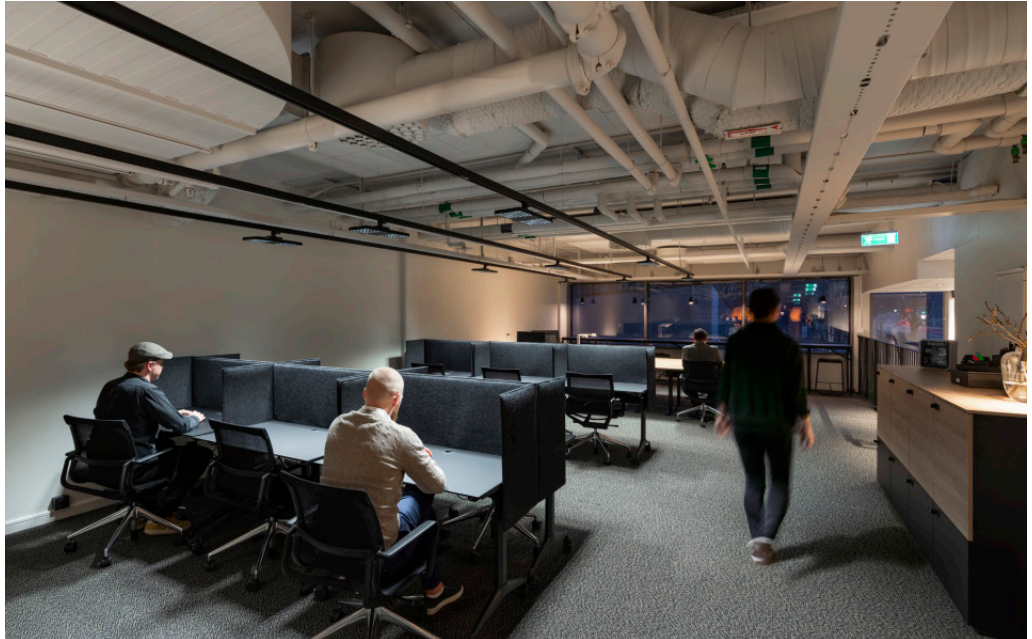

Integrated office lighting

A zoned, ceiling-integrated lighting concept with especially small luminaires achieves a calm ceiling appearance. Downlights with excellent glare control and oval wide flood light distribution support office activities and provide uniform general light.

